

WHERE IS THE FAULT ? ECFL30 GIVES THE ANSWER !



Four instruments in one

- **Active bridge** for accurate location of faults where the level of disturbing voltages are low
- **Wheatstone bridge** for location of faults where the level of disturbing voltages are high
- **Graaf** for fault locator accurate fault location on totally water-soaked cable where the disturbing voltages are usually high and intermittent
- **TDR** to find low impedance faults and splits causing cross talk between the pairs

APPLICATIONS

The **CABLE FAULT LOCATOR ECFL 30** hand-held instrument is intended to test the quality of telecom cables and to locate cable faults. That combined instrument provides several tools for the accurate location of DC/AC faults on the line:

Resistance Measurements

- Loop resistance
- Resistance difference
- Insulation resistance

Capacitance Measurements

- Cable capacitance
- Capacitive balance

DC Fault Location Methods

- Murray
- 3 Point
- K upfm uller
- Repeated K upfm uller

AC Fault Location Methods

- Interruption
- Repeated K upfm uller

Graaf Fault Location Method

- End to end Master-Slave measurement
- Fault location on totally water-soaked cable

TDR Measurements

- Single pair
- Double Pair Measurements
- XTALK
- Comparison to Memory

AC-DC Voltage measurements

ECFL 30 has a graphic display an easy to use menu system and a many-sided help system providing extremely simple operation for the user. Operation is made extremely comfortable by means of pre-defined automatic test sequences.

Automatic test sequences

- Cable State Survey to find the best test method
- Quick Test of main parameters
- Quality Test Sequence

USB ports for result transfer

- USB B device-port for direct PC connection
- USB A host-port for USB stick (Indirect transfer)

The indirect transfer is advantageous for the user who does not have administrative right to install a special driver to his PC.

ECFL 30 is suitable for the remote control of loop closing devices on the far end. Utilizing that feature just one person can perform measurements during which the far endings of the tested pair should be opened or closed (e.g K upfm uller method).

Remote controllable far end devices

- ELC 30 loop closing device to open or close the far end of the tested cable
- ECFL 30S slave unit to perform synchronic end to end Graaf measurement and open or close the far end of the tested cable.

The obtained test results can be stored in the internal memory of the instrument and transferred to PC.

FAULT LOCATOR MODES

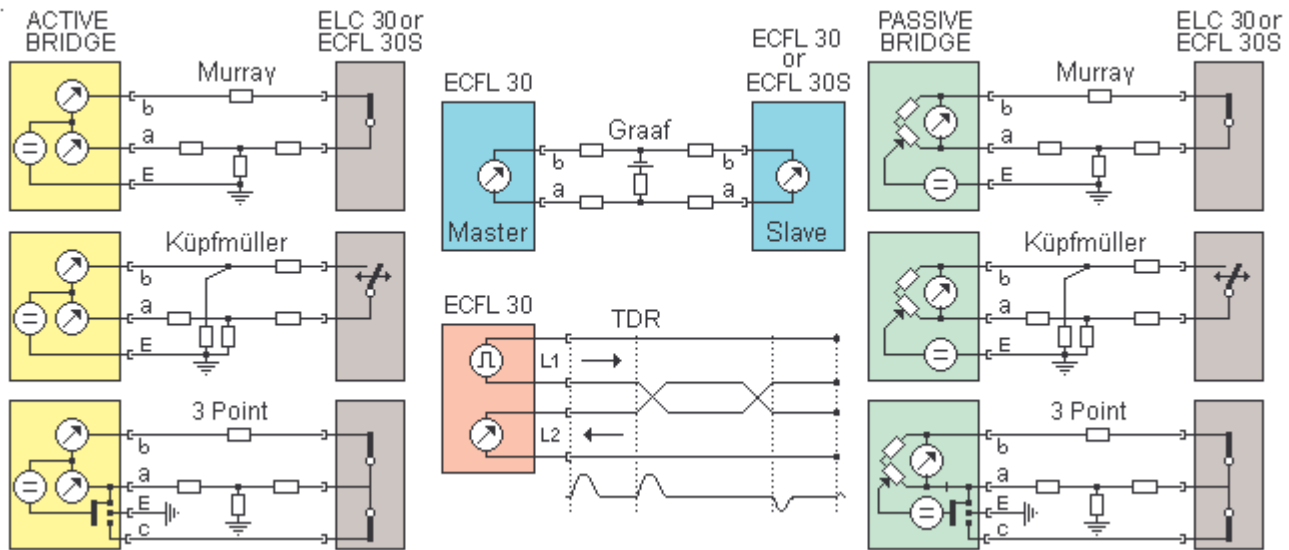

SPECIFICATIONS

TDR

Measuring ranges

For non loaded cable (at $V/2=100$).....up to 32 km
 For loaded cable (at $V/2=10$).....6.4 to 32 km
 The maximum range depends on cable type and condition

Evaluation of results

With Cursor and MarkerIn meters
 Refreshing of waveform ~4/sec
 Zoom Maximum 16

Accuracy

Fault location..... 0.2% of range
 Resolution0.01 m

Propagation Velocity

For non loaded cables
 $V/2$45 to 149 m/ μ s
 VOP..... 30 to 99 %

For loaded cables
 $V/2$1.2 to 30 m/ μ s
 VOP..... 0.8 to 20 %

Pulse characteristics

Widths for non loaded cable 4 ns to 6 μ s
 Widths for loaded cable330 μ s
 Amplitude:3 to 12 Vpp into 120 Ω
 Automatically changed with gain and width.

Line Connection

Impedance 120 Ω balanced
 Balance control 50 to 270 Ω

Gain Control

Range..... 0 to 90 dB
 Steps..... 6 dB/Step

Distance dependent amplitude correction

Number of steps..... 10

ACTIVE BRIDGE

Voltage

DC voltage.....up to 400 V
 AC voltage up to 250 V eff
 Accuracy $\pm 3\% \pm 1$ V
 Frequency range 15 to 300 Hz
 Input resistance 2 M Ω

Loop Resistance

Measuring range..... 1 Ω to 10 k Ω
 Accuracy $\pm 0.3\% \pm 0.1$ Ω

Resistance Difference

Loop resistance range 10 Ω to 5000 Ω
 Accuracy $\pm 0.2\%$ of RI ± 0.2 Ω

Insulation Resistance

Measuring range..... 10 k Ω to 300 M Ω
 Measuring voltage 100 V
 Accuracy 2 to 5% ± 1 k Ω

Capacitance

Measuring range..... 1 nF to 2 (10) μ F
 Measuring voltage 11 Hz, 100 V
 Accuracy $\pm 2\% \pm 0.2$ nF

Capacitive Balance

Measuring range..... 1 nF to 2000 nF
 Measuring voltage 11 Hz, 100 V
 Accuracy of Lx/L value ± 0.2 %

DC Fault Location

Test Methods..... Murray, Küpfmüller, 3 Point
 Loop resistance range 1 Ω to 10 k Ω
 Fault resistance range up to 100 M Ω
 Measuring voltage 100 V
 Accuracy
 Fault resistance < 1M Ω ± 0.2 %
 Fault resistance 1 M Ω to 5 M Ω ± 0.3 %
 Fault resistance 5 M Ω to 25 M Ω ± 0.5 %
 Fault resistance 25 M Ω to 100 M Ω ± 2 %

AC Fault Location Interruption

Rangeup to 20 km (Depends on cable typ)
 Accuracy $\pm 2\% \pm 0.2$ nF

PASSIVE BRIDGE**Loop Resistance**

Measuring range 1 Ω to 10 k Ω
 Accuracy $\pm 0.3\%$ $\pm 0.3 \Omega$

Insulation Resistance

Measuring modes Quick measurement,
 Quality measurement

Measuring ranges

Quick measurement 10 k Ω to 300 M Ω
 Quality measurement up to 10 G Ω
 Measuring voltage 100 V

Accuracy

10 k Ω to 50 M Ω 5 % ± 1 k Ω
 50 M Ω to 100 M Ω 10 %
 100 M Ω to 5 000 M Ω 20 %
 5 000 M Ω to 10 000 M Ω 30 %

Resistance Difference

Loop resistance range 1 Ω to 5000 Ω
 Accuracy $\pm 0.2\%$ of RI $\pm 0.2 \Omega$

Resolution of Lx/L (Mk)-value

In range R < 10% 1/ 10000
 In range R > 10% 1/1000

DC Fault Location

Test methods Murray, K pfm ller, 3 Point
 Loop resistance range 1 Ω to 10 k Ω
 Fault resistance range up to 100 M Ω
 Measuring voltage 100 V

Accuracy (RI=2 k Ω , Lx/L=0,1 to 1)

Fault resistance < 1 M Ω 0.2 %
 Fault resistance 1 M Ω to 5 M Ω 0.3 %
 Fault resistance 5 M Ω to 25 M Ω 0.5 %
 Fault resistance 25 M Ω to 100 M Ω 2 %
 Resolution of Lx/L (Mk) value 1/1000

AC Fault Location K pfm ller Method

Loop resistance range 1 Ω to 10 k Ω
 Fault resistance range up to 25 M Ω
 Measuring voltage 11 Hz, 100 V
 Accuracy (RI=2 k Ω , Lx/L=0,1 to 1)

Fault resistance < 1 M Ω $\pm 0.3\%$
 Fault resistance 1 M Ω to 5 M Ω $\pm 0.5\%$
 Fault resistance 5 M Ω to 25 M Ω $\pm 1.0\%$
 Resolution of M value 1/1000

AC Capacitive Balance

Measuring range 10 nF to 2000 nF
 Accuracy of Lx/L value $\pm 0.2\%$
 Measuring voltage 11 Hz, 100 V

Resolution of Lx/L value

In range Lx/L=0.9 to 1.1 1/10000
 In range Lx/L<0.9 or Lx/L>1.1 1/1000

PRE MEASUREMENTS**Disturbing Voltage**

Measuring mode Repeated measurement
 Measuring range
 DC voltage up to 400 V
 AC voltage up to 250 V eff
 Accuracy $\pm 3\%$ ± 1 V
 Frequency range 15 to 300 Hz
 Input resistance 2 M Ω

Loop Resistance

Measuring mode Repeated measurement
 Measuring range 1 Ω to 10 k Ω
 Accuracy $\pm 0.5\%$ $\pm 0.2 \Omega$

Insulation Resistance

Measuring mode Repeated measurement
 Measuring range 10 k Ω to 300 M Ω
 Measuring time ~ 3 sec
 Measuring voltage 100 V
 Accuracy (without disturbing voltages)
 in % of test result 20 %

AUTOMATIC QUICK TEST**Disturbing Voltage**

Measuring range up to 400 V DC, 250 V AC
 Test results Vab, VaE and VbE

Insulation

Measuring range 10 k Ω to 300 M Ω
 Measuring time ~3 x 20 sec

Capacitance

Measuring range 10 to 2000 nF

Capacitive Balance

Test result Unbalance %
 Measuring voltage 11 Hz, 100 V

AUTOMATIC QUALITY TEST**Insulation**

Measuring range 10 k Ω to 10 000 M Ω
 Measuring time ~3 x 35 sec

Capacitance

Measuring range 10 to 2000 nF

Capacitive Balance

Test result Unbalance %
 Resolution 1/1000

Loop Resistance

Measuring range 1 Ω to 10k Ω
 Accuracy $\pm 0.3\%$ $\pm 0.1 \Omega$

Resistance Difference

Loop resistance range 10 Ω to 5 k Ω
 Resolution 1/1000

GENERAL SPECIFICATIONS**Power Supply**

Internal rechargeable NiMH battery pack
 Operation time..... approx. 8 hours
 (Without backlight)
 Charging (without taking the battery pack out)
 From 90 to 260 V mains..... with mains adapter
 From 12 V car batterywith car adapter
 Charging time.....less than 3 hours
 (Fast charging mode)
 Display..... 320 x 240 dot graphic LCD
 with backlight

Connectors

Connector for mains adapter2.1/5.5mm coax
 L1 and L2 line
 connectors..... 4 mm banana sockets
 Ground connector4 mm banana socket
 USB A USB 1.1 host port for USB-Stick
 (FAT 16 file system supported)
 USB B USB 1.1 device port to connect PC
 (Device driver provided)

Over Voltage Protection

Between a and b
 or ground 500 V DC, 350 V AC
 Longitudinal voltage 60 V AC

Ambient temperature ranges

Reference 23±5°C
 Rel. humidity 45% to 75%*
 Normal operation 0 to +40°C
 Rel. humidity 30% to 75% *(<25g/m³)
 Limits of operation -5 to +45°C
 Rel. humidity 5% to 95% *(< 29 g/m³)
 Storage and transport..... -40 to +70°C
 Rel. humidity 95% at +45°C *(<35g/m³)

Memory Locations

For test results..... 50
 For cable parameter 50

Mechanical Data

Dimensions..... 224 x 160 x 75 mm
 Weight (Including battery pack).....ca. 1.8 kg

* Without condensation

ORDERING INFORMATION**CABLE FAULT LOCATOR**

ECFL30419 000-000

Including:

Operating manual OM 419 000-000
 Short form operation instruction .. ML 419 000 000
 Calibration Certificate CC 419 000 000
 CD, containing CD 419 000 000
 Instrument software (Firmware)
 Demo program
 PC- program for data transfer
 Operating manual in pdf
 Ground cable Y 107-425
 2-wire test lead (red/black) Y 107-426
 2- wire test lead (blue/yellow) Y 107-427
 AC Mains adapter (90 to 260V)
 European version Y 146-017
 UK version Y 146-021
 US version Y 146-024
 USB cable Y 107-389
 Battery pack (built-in)..... Y 355-140 000B
 Carrying case..... Y 147-025

Options

Loop closing device ELC 30421-000-000
 Intelligent Slave ECFL 30S425-000-000
 Data transfer SW 419-510-000
 Car battery adapter Y 367-000